

PART NUMBER	SIZE	"R"	"O"	"H"	"S" MIN	"B" MIN	"L"
5233920	2"	90"	30"	30"	2"	2"	47 1/8"
5233981	2 1/2"	90"	30"	30"	3"	2 1/4"	47 1/8"
5234081	3"	90"	30"	30"	3 1/8"	2 1/2"	47 1/8"
5233852	4"	90"	30"	30"	3 3/8"	3 1/4"	47 1/8"
5233872	5"	90"	30"	30"	3 5/8"	4 1/4"	47 1/8"

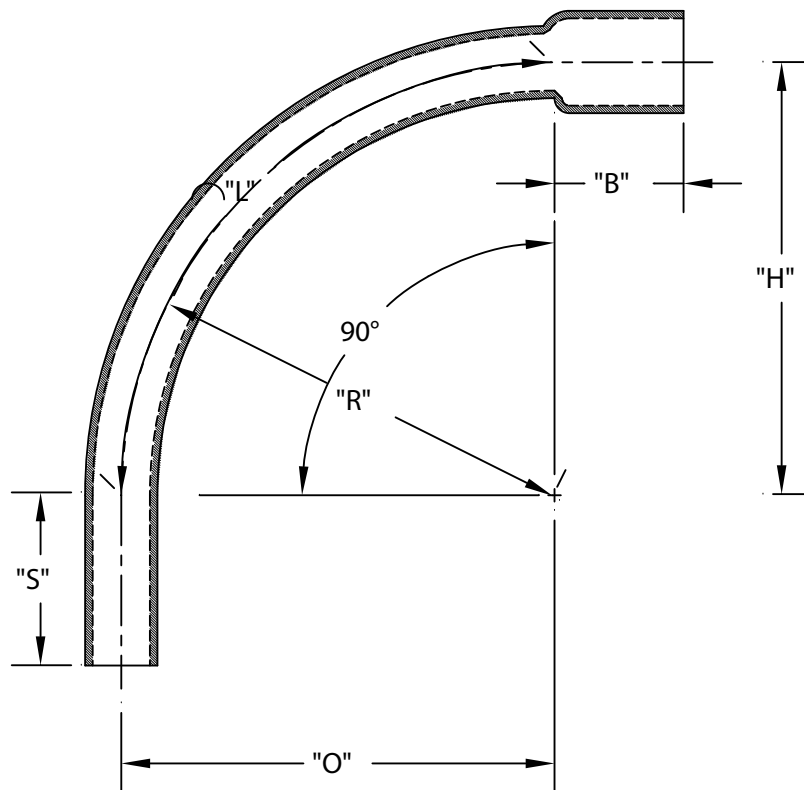

ETL LISTED
CONFORMS TO UL651
ETL CONTROL #3107144
CONFORMS TO NEMA TC3
SEE NEC ARTICLE 352 FOR USE
MATERIAL IS RIGID PVC
BEND TOLERANCE IS $\pm 2^\circ$
"B" TOLERANCE IS $-1/8", +1/2"$



CANTEX
INC.
Fort Worth, TEXAS

90° Elbows Bell End
Schedule 40 30" Radius Elbows

Drawn By: CD Branch

Date: 10/15/07

Ref.