

PART NUMBER	SIZE	"R"	"O"	"H"	"S" MIN	"B" MIN	"L"
5233995	1 ¼"	48"	3 ⅝"	18 ⅜"	2"	1 ½"	18 ⅞"
5233984	2"	48"	3 ⅝"	18 ⅜"	2"	2"	18 ⅞"
5233907	3"	48"	3 ⅝"	18 ⅜"	3 ⅛"	2 ½"	18 ⅞"
5233932	4"	48"	3 ⅝"	18 ⅜"	3 ⅜"	3 ¼"	18 ⅞"
5233931	5"	48"	3 ⅝"	18 ⅜"	3 ⅝"	4 ¼"	18 ⅞"
5233862	6"	48"	3 ⅝"	18 ⅜"	3 ¾"	5 ½"	18 ⅞"

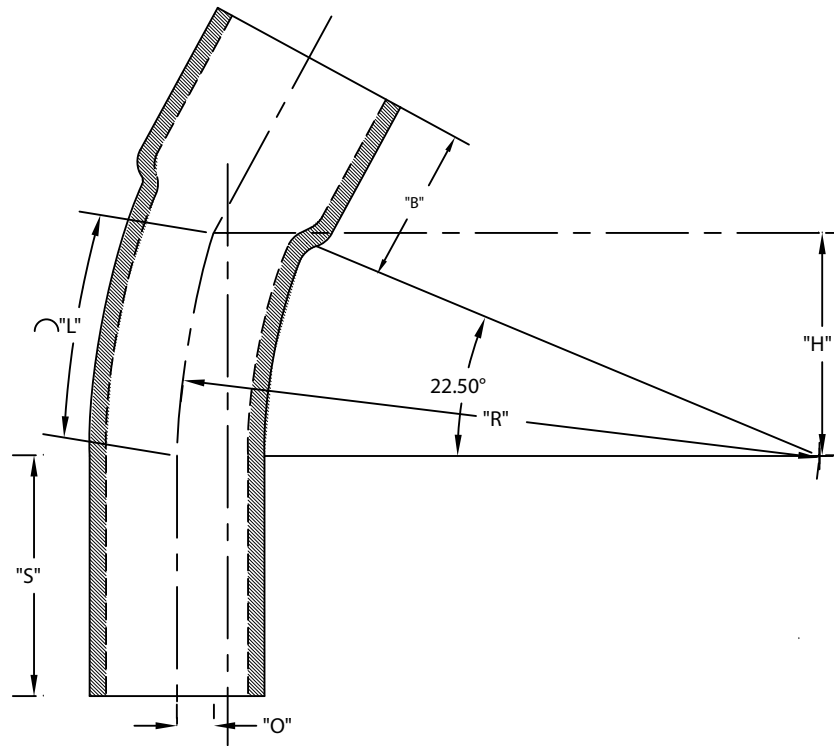

ETL LISTED
 CONFORMS TO UL651
 ETL CONTROL #3107144
 CONFORMS TO NEMA TC3
 SEE NEC ARTICLE 352 FOR USE
 MATERIAL IS RIGID PVC
 BEND TOLERANCE IS $\pm 2^\circ$
 " B " TOLERANCE IS - ⅛", + ½"



22-1/2° Elbows Bell End
 Schedule 40 48" Radius Elbows

Drawn By: CD Branch

Date: 10/15/07

Ref.