

PART NUMBER	SIZE	"R"	"D"	"H"	"S" MIN	"B" MIN	"L"
5234014	2"	150"	11 3/8"	57 3/8"	2"	1 1/8"	58 7/8"
5233887	3"	150"	11 3/8"	57 3/8"	3 1/8"	1 5/8"	58 7/8"
5233870	4"	150"	11 3/8"	57 3/8"	3 3/8"	1 3/4"	58 7/8"
5233960	5"	150"	11 3/8"	57 3/8"	3 5/8"	2"	58 7/8"
5234055	6"	150"	11 3/8"	57 3/8"	3 3/4"	2 1/8"	58 7/8"

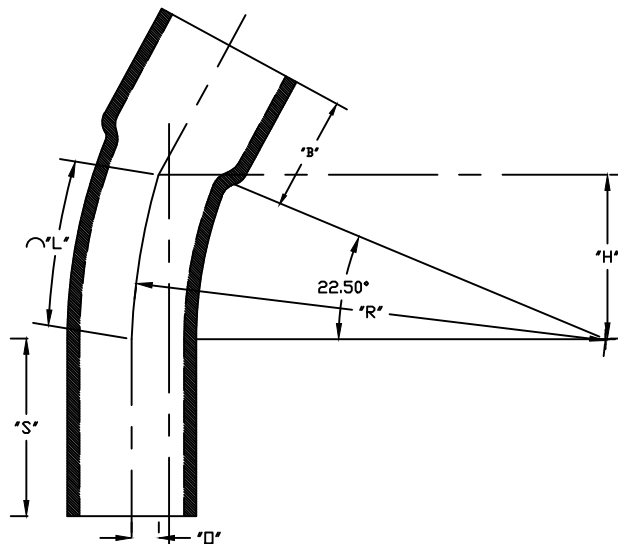

ETL LISTED  
 CONFORMS TO UL651  
 ETL CONTROL #3107144  
 CONFORMS TO NEMA TC3  
 SEE NEC ARTICLE 352 FOR USE  
 MATERIAL IS RIGID PVC  
 BEND TOLERANCE IS ±2°



<b>CANTEX</b> INC. Fort Worth, TEXAS		
22-1/2° Elbows Bell End Schedule 40 150" Radius Elbows		
Drawn By: O.M.	Date: 5/12/17	Ref. 5234014