

PART NUMBER	SIZE	"R"	"O"	"H"	"S" MIN	"B" MIN	"L"
5233844	1"	18"	18"	18"	1 7/8"	1 1/2"	28 1/4"
5233923	1 1/4"	18"	18"	18"	2"	1 1/2"	28 1/4"
5233839	1 1/2"	18"	18"	18"	2"	2"	28 1/4"
5233846	2"	18"	18"	18"	2"	2 1/4"	28 1/4"
5233856	2 1/2"	18"	18"	18"	3"	2 1/4"	28 1/4"
5233850	3"	18"	18"	18"	3 1/8"	2 1/2"	28 1/4"

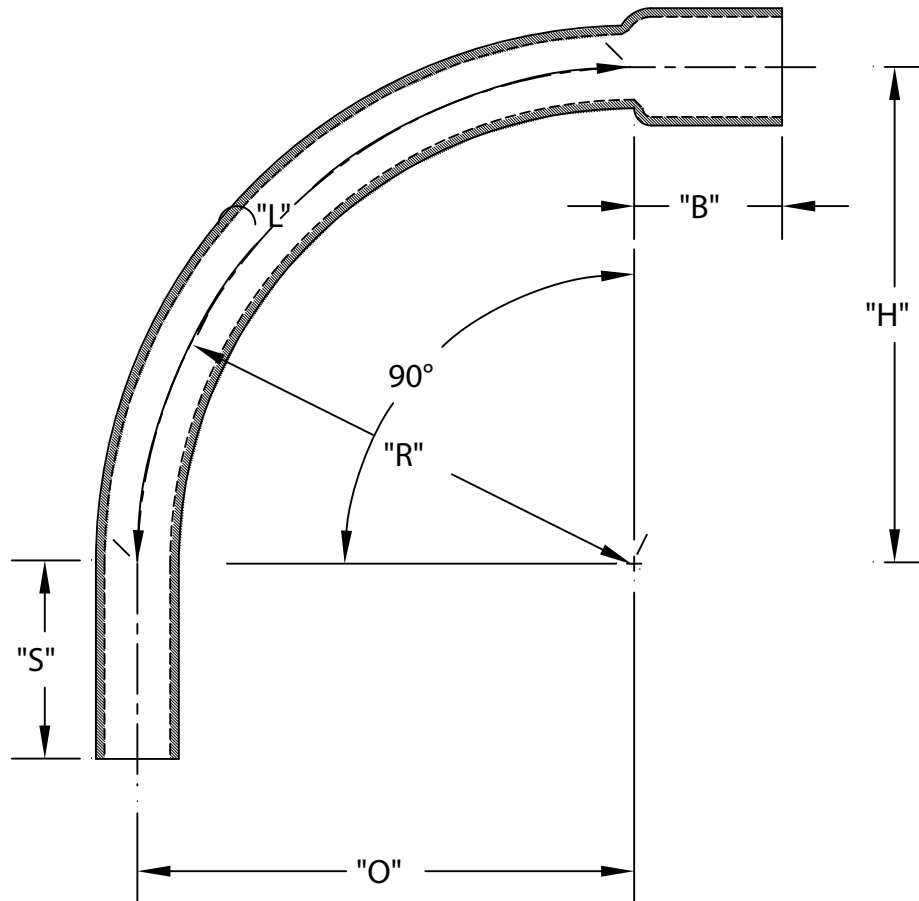

ETL LISTED  
 CONFORMS TO UL651  
 ETL CONTROL #3107144  
 CONFORMS TO NEMA TC3  
 SEE NEC ARTICLE 352 FOR USE  
 MATERIAL IS RIGID PVC  
 BEND TOLERANCE IS  $\pm 2^\circ$   
 "B" TOLERANCE IS  $-1/8"$ ,  $+1/2"$



**CANTEX**  
 INC.  
 Fort Worth, TEXAS

90° Elbows Bell End  
 Schedule 40 18" Radius Elbows

Drawn By: CD Branch

Date: 10/15/07

Ref.