

PART NUMBER	SIZE	"R"	"O"	"H"	"S" MIN	"B" MIN	"L"
5233786	2"	60"	60"	60"	2"	2"	94 ¼ "
5233819	3"	60"	60"	60"	3 ⅛ "	2 ½"	94 ¼ "
5233854	4"	60"	60"	60"	3 ⅜"	3 ¼"	94 ¼ "
5233885	5"	60"	60"	60"	3 ⅝"	4 ¼"	94 ¼ "
5233886	6"	60"	60"	60"	3 ¾"	5"	94 ¼ "

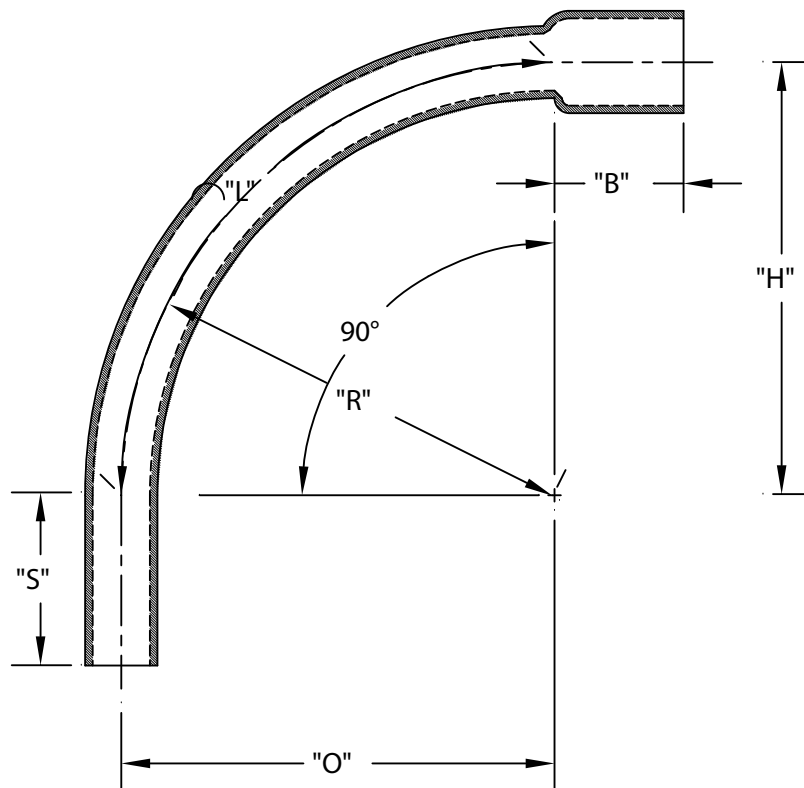

ETL LISTED
 CONFORMS TO UL651
 ETL CONTROL #3107144
 CONFORMS TO NEMA TC3
 SEE NEC ARTICLE 352 FOR USE
 MATERIAL IS RIGID PVC
 BEND TOLERANCE IS $\pm 2^\circ$
 "B" TOLERANCE IS $-\frac{1}{8}"$, $+\frac{1}{2}"$



CANTEX
INC.
Fort Worth, TEXAS

90° Elbows Bell End
Schedule 40 60" Radius Elbows

Drawn By: CD Branch

Date: 10/15/07

Ref.