

PART NUMBER	SIZE	"R"	"O"	"H"	"S" MIN	"B" MIN	"L"
5233746	1 1/4"	7 1/4"	1"	3 5/8"	2"	1"	3 13/16"
5233748	2"	9 1/2"	1 1/4"	4 3/4"	2"	1 1/8"	5"
5233750	3"	13	1 3/4"	6 1/2"	3 1/8"	1 5/8"	6 13/16"
5233751	3 1/2"	15	2"	7 9/16"	3 1/4"	1 1/16"	7 7/8"
5233776	4"	16	2 1/16"	8"	3 3/8"	1 3/4"	8 3/8"
5233753	5"	24	3 3/16"	12"	3 5/8"	2"	12 9/16"
5233754	6"	30	4"	15"	3 3/4"	2 1/8"	15 1/16"

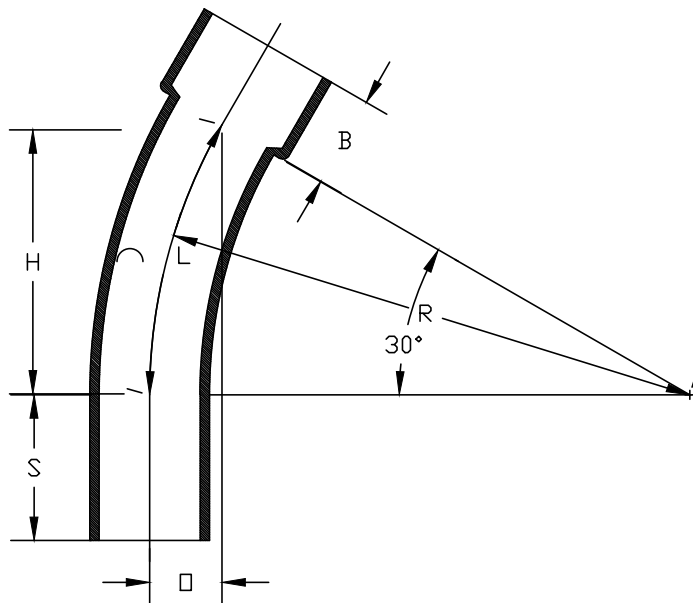

ETL LISTED  
 CONFORMS TO UL651  
 ETL CONTROL #3107144  
 CONFORMS TO NEMA TC3  
 SEE NEC ARTICLE 352 FOR USE  
 MATERIAL IS RIGID PVC  
 BEND TOLERANCE IS ±2°



<b>CANTEX</b> INC. Fort Worth, TEXAS		
30° Elbows Bell End Schedule 40 Standard Radius Elbows		
Drawn By: CD Branch	Date: 11/15/18	Ref.