

PART NUMBER	SIZE	"R"	"O"	"H"	"S" MIN	"B" MIN	"L"
5221104	1"	24"	7"	17"	1 7/8"	1 1/2"	18 7/8"
5221101	2"	24"	7"	17"	2"	2"	18 7/8"
5122943	2 1/2 "	24"	7"	17"	3"	2 1/4"	18 7/8"
5221014	3"	24"	7"	17"	3 1/8 "	2 1/2"	18 7/8"
5221089	4"	24"	7"	17"	3 3/8"	3 1/4"	18 7/8"

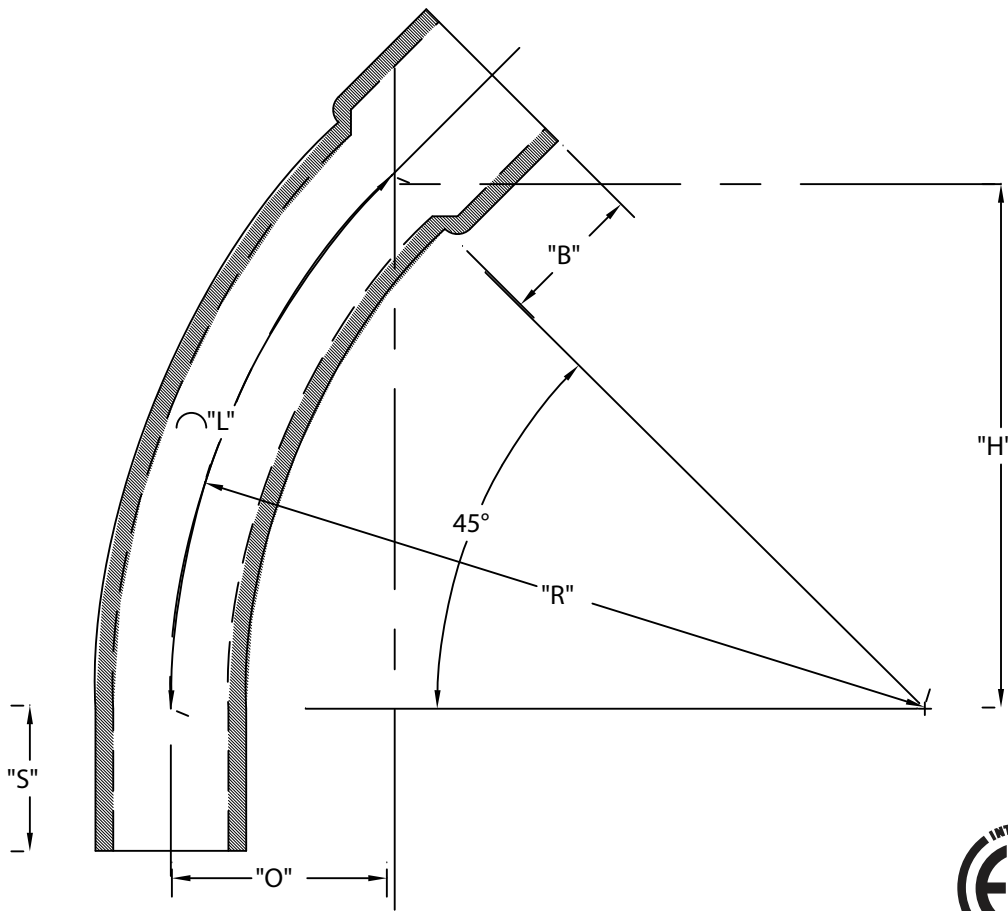

ETL LISTED
 CONFORMS TO UL651
 ETL CONTROL #3107144
 CONFORMS TO NEMA TC3
 SEE NEC ARTICLE 352 FOR USE
 MATERIAL IS RIGID PVC
 BEND TOLERANCE IS $\pm 2^\circ$
 "B" TOLERANCE IS $-1/8"$, $+1/2"$



CANTEX INC. Fort Worth, TEXAS		
45° Elbows Bell End Schedule 80 24" Radius Elbows		
Drawn By: CD Branch	Date: 10/15/07	Ref.