

PART NUMBER	SIZE	"R"	"O"	"H"	"S" MIN	"B" MIN	"L"
5221098	2"	36"	10 ½ "	25 7/16 "	2"	2"	28 ¼ "
5221150	2 ½ "	36"	10 ½ "	25 7/16 "	3"	2 ¼"	28 ¼ "
5221077	3"	36"	10 ½ "	25 7/16 "	3 ⅛ "	2 ½"	28 ¼ "
5219821	4"	36"	10 ½ "	25 7/16 "	3 ¾"	3 ¼"	28 ¼ "

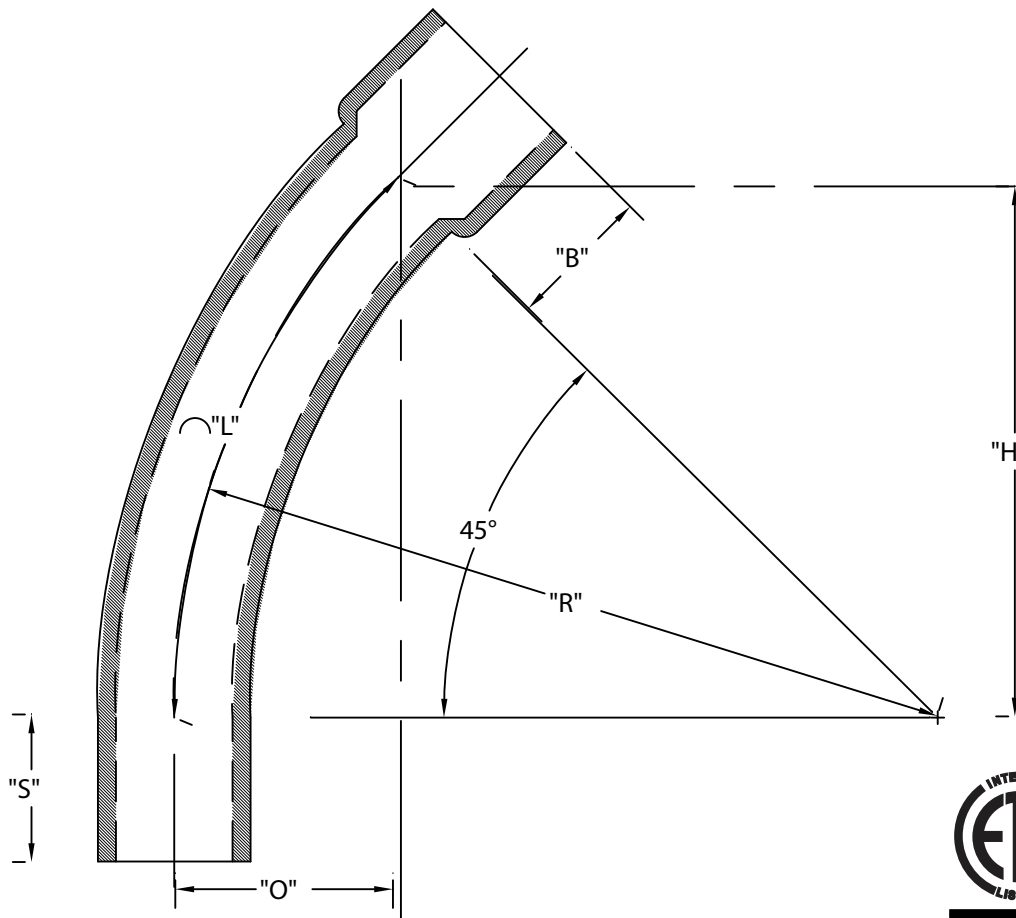

ETL LISTED
 CONFORMS TO UL651
 ETL CONTROL #3107144
 CONFORMS TO NEMA TC3
 SEE NEC ARTICLE 352 FOR USE
 MATERIAL IS RIGID PVC
 BEND TOLERANCE IS ±2°
 "B" TOLERANCE IS -1/8", +1/2"



CANTEX
 INC.
 Fort Worth, TEXAS

45° Elbows Bell End
 Schedule 80 36" Radius Elbows

Drawn By: CD Branch

Date: 10/15/07

Ref.