

PART NUMBER	SIZE	"R"	"O"	"H"	"S" MIN	"B" MIN	"L"
5221018	1"	24"	24"	24"	1 7/8"	1 1/2"	37 11/16 "
5219824	1 1/4 "	24"	24"	24"	2"	1 1/2"	37 11/16 "
5221015	1 1/2 "	24"	24"	24"	2"	2"	37 11/16 "
5121036	2"	24"	24"	24"	2"	2"	37 11/16 "
5122028	2 1/2 "	24"	24"	24"	3"	2 1/4"	37 11/16 "
5121031	3"	24"	24"	24"	3 1/8 "	2 1/2"	37 11/16 "
5221022	4"	24"	24"	24"	3 3/8"	3 1/4"	37 11/16 "

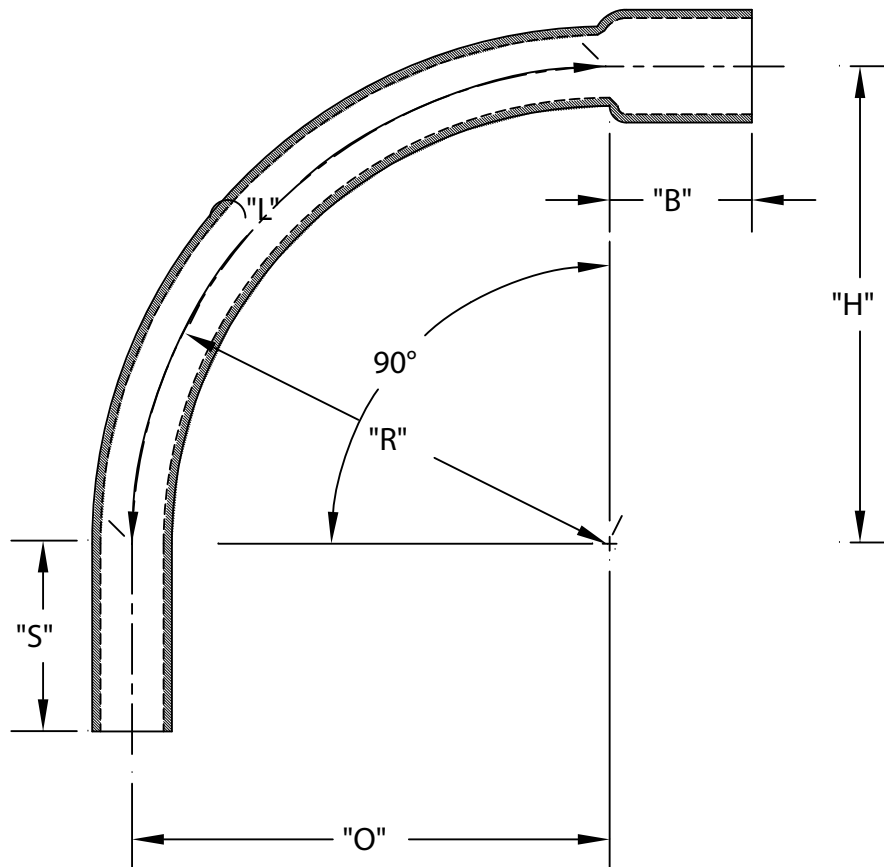

ETL LISTED
 CONFORMS TO UL651
 ETL CONTROL #3107144
 CONFORMS TO NEMA TC3
 SEE NEC ARTICLE 352 FOR USE
 MATERIAL IS RIGID PVC
 BEND TOLERANCE IS $\pm 2^\circ$
 "B" TOLERANCE IS $-1/8", +1/2"$



CANTEX

INC.
Fort Worth, TEXAS

90° Elbows Bell End
Schedule 80 24" Radius Elbows

Drawn By: CD Branch

Date: 10/15/07

Ref.