

PART NUMBER	SIZE	"R"	"O"	"H"	"S" MIN	"B" MIN	"L"
5221006	1 ¼"	7 ¼"	2 ⅛"	5 ⅛"	2"	1 ½"	5 ⅛"
5221007	1 ½"	8 ¼"	2 ⅞"	5 ⅜"	2"	2"	6 ½"
5221008	2"	9 ½"	2 ⅞"	6 ¾"	2"	2"	7 ½"
5221009	2 ½"	10 ½"	3 ⅛"	7 ⅞"	3"	2 ¼"	8 ¼"
5221010	3"	13"	3 ⅜"	9 ⅜"	3 ⅛"	2 ½"	10 ⅜"
5221011	4"	16"	4 ⅜"	11 ⅜"	3 ⅜"	3 ¼"	12 ⅜"
5221012	5"	24"	7"	17"	3 ⅝"	4 ¼"	18 ⅞"
5221013	6"	30"	8 ⅞"	21 ¼"	3 ¾"	5"	23 ⅞"

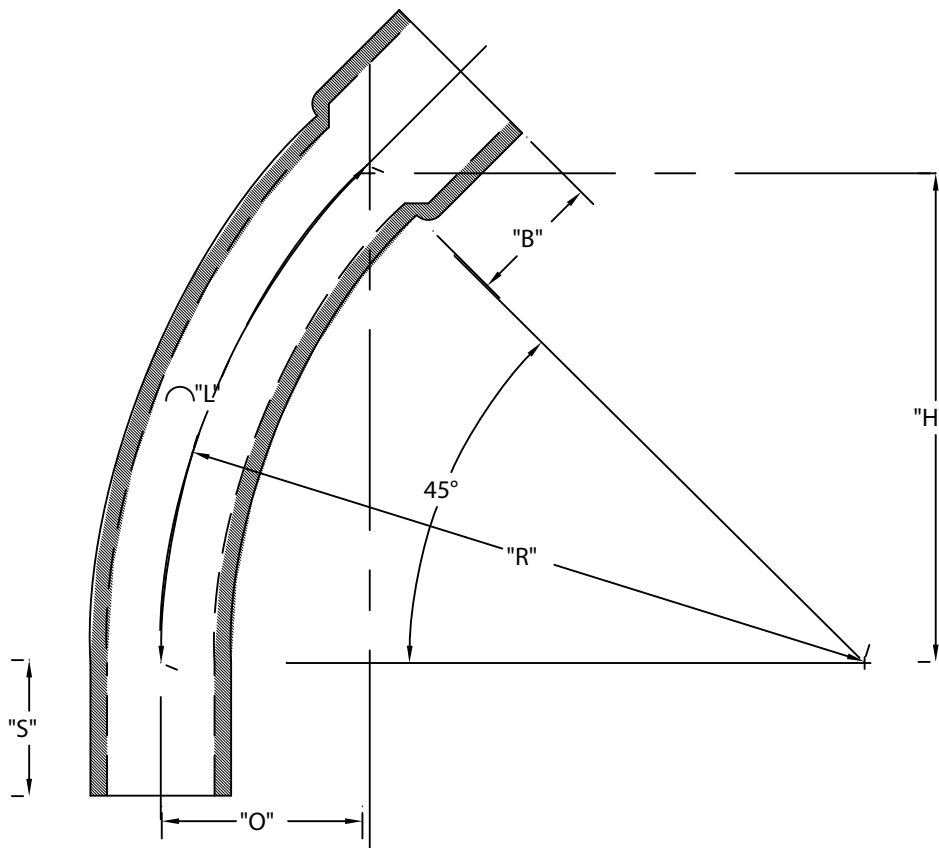

ETL LISTED
 CONFORMS TO UL651
 ETL CONTROL #3107144
 CONFORMS TO NEMA TC3
 SEE NEC ARTICLE 352 FOR USE
 MATERIAL IS RIGID PVC
 BEND TOLERANCE IS $\pm 2^\circ$
 "B" TOLERANCE IS $-\frac{1}{8}"$, $+\frac{1}{2}"$



CANTEX
 INC.
 Fort Worth, TEXAS

45° Elbows Bell End
 Schedule 80 Standard Radius Elbows

Drawn By: CD Branch

Date: 10/15/07

Ref.