

PART NUMBER	SIZE	"R"	"O"	"H"	"S" MIN	"B" MIN	"L"
5136686	4"	60"	4 1/16"	23"	3 3/8"	N/A	23 1/16"
5136691	5"	60"	4 1/16"	23"	3 5/8"	N/A	23 1/16"
5121118	6"	60"	4 1/16"	23"	3 3/4"	N/A	23 1/16"

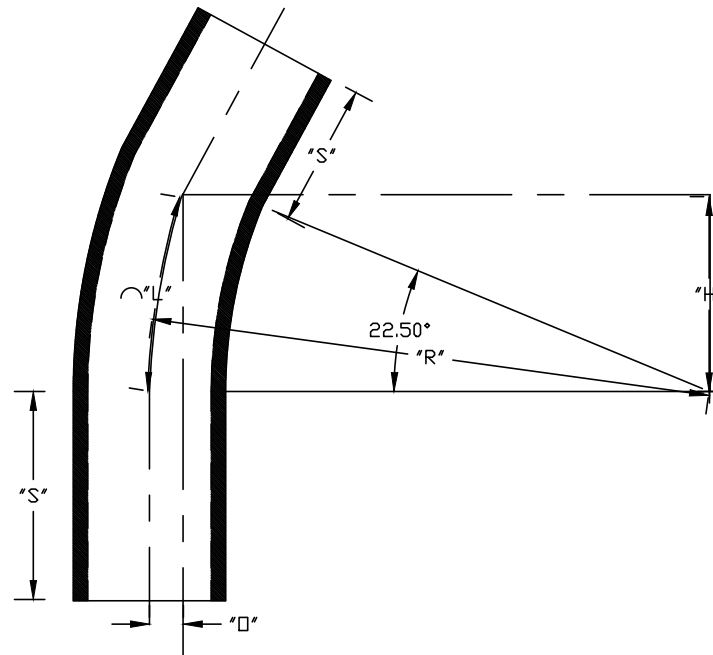

ETL LISTED
 CONFORMS TO UL651
 ETL CONTROL #3107144
 CONFORMS TO NEMA TC3
 SEE NEC ARTICLE 352 FOR USE
 MATERIAL IS RIGID PVC
 BEND TOLERANCE IS ±2°



CANTEX INC. Fort Worth, TEXAS		
22-1/2° Elbows Plain End Schedule 80 60" Radius Elbows		
Drawn By: D. Gwinn	Date: 2/14/19	Ref. 5136686