

PART NUMBER	SIZE	"R"	"□"	"H"	"S" MIN	"B" MIN	"L"
5136347	1 ¼"	36"	4 13/16"	18"	2"	N/A	18 7/8"
5133974	1 ½"	36"	4 13/16"	18"	2"	N/A	18 7/8"
5133792	2"	36"	4 13/16"	18"	2"	N/A	18 7/8"
5133807	2 ½"	36"	4 13/16"	18"	3"	N/A	18 7/8"
5133793	3"	36"	4 13/16"	18"	3 ½"	N/A	18 7/8"
5133790	4"	36"	4 13/16"	18"	3 ¾"	N/A	18 7/8"
5133931	5"	36"	4 13/16"	18"	3 5/8"	N/A	18 7/8"
5133791	6"	36"	4 13/16"	18"	3 ¾"	N/A	18 7/8"

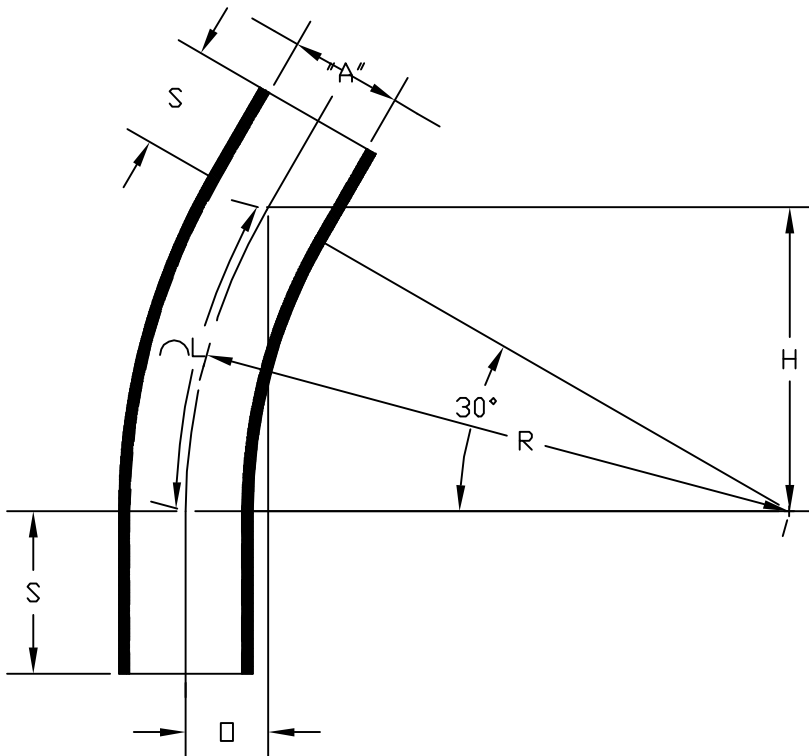

ETL LISTED
 CONFORMS TO UL651
 ETL CONTROL #3107144
 CONFORMS TO NEMA TC3
 SEE NEC ARTICLE 352 FOR USE
 MATERIAL IS RIGID PVC
 BEND TOLERANCE IS $\pm 2^\circ$



CANTEX
 INC.
 Fort Worth, TEXAS

30° Elbows Plain End
 Schedule 40 36" Radius Elbows

Drawn By: CD Branch | Date:10/15/07 | Ref.