

PART NUMBER	SIZE	"R"	"O"	"H"	"S" MIN	"B" MIN	"L"
5133975	1"	36"	2 3/4"	13 3/4"	1 7/8"	N/A	14 1/8"
5133997	1 1/4"	36"	2 3/4"	13 3/4"	2"	N/A	14 1/8"
5134103	1 1/2"	36"	2 3/4"	13 3/4"	2"	N/A	14 1/8"
5133851	2"	36"	2 3/4"	13 3/4"	2"	N/A	14 1/8"
5133937	2 1/2"	36"	2 3/4"	13 3/4"	3"	N/A	14 1/8"
5133904	3"	36"	2 3/4"	13 3/4"	3 1/8"	N/A	14 1/8"
5136437	3 1/2"	36"	2 3/4"	13 3/4"	3 1/4"	N/A	14 1/8"
5133853	4"	36"	2 3/4"	13 3/4"	3 3/8"	N/A	14 1/8"
5133881	5"	36"	2 3/4"	13 3/4"	3 5/8"	N/A	14 1/8"
5133905	6"	36"	2 3/4"	13 3/4"	3 3/4"	N/A	14 1/8"

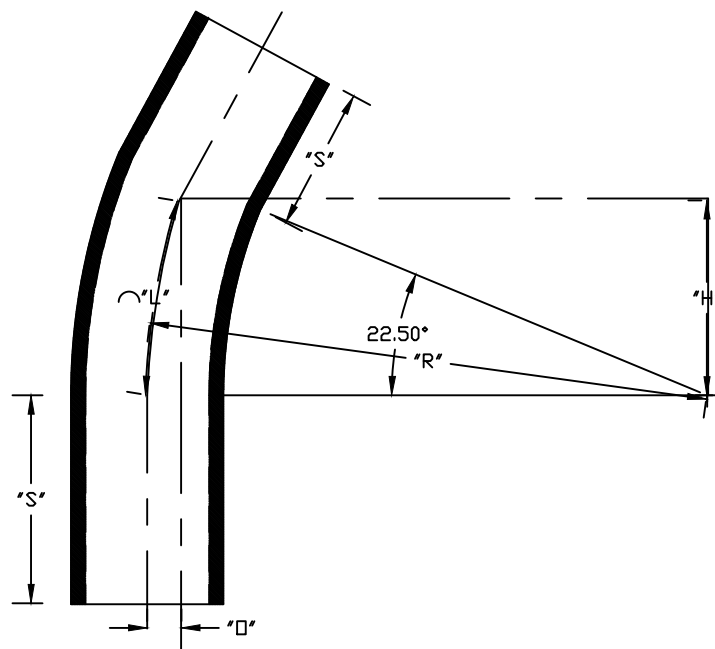

ETL LISTED  
 CONFORMS TO UL651  
 ETL CONTROL #3107144  
 CONFORMS TO NEMA TC3  
 SEE NEC ARTICLE 352 FOR USE  
 MATERIAL IS RIGID PVC  
 BEND TOLERANCE IS  $\pm 2^\circ$



<b>CANTEX</b> INC. Fort Worth, TEXAS		
22-1/2° Elbows Plain End Schedule 40 36" Radius Elbows		
Drawn By: O.M	Date: 5/12/17	Ref. 5133851