

PART NUMBER	SIZE	"R"	"O"	"H"	"S" MIN	"B" MIN	"L"
5233953	4"	30"	8 3/4"	21 1/4"	3 3/8"	3 1/4"	23 9/16"
5133970	5"	30"	8 3/4"	21 1/4"	3 3/8"	4 1/4"	23 9/16"

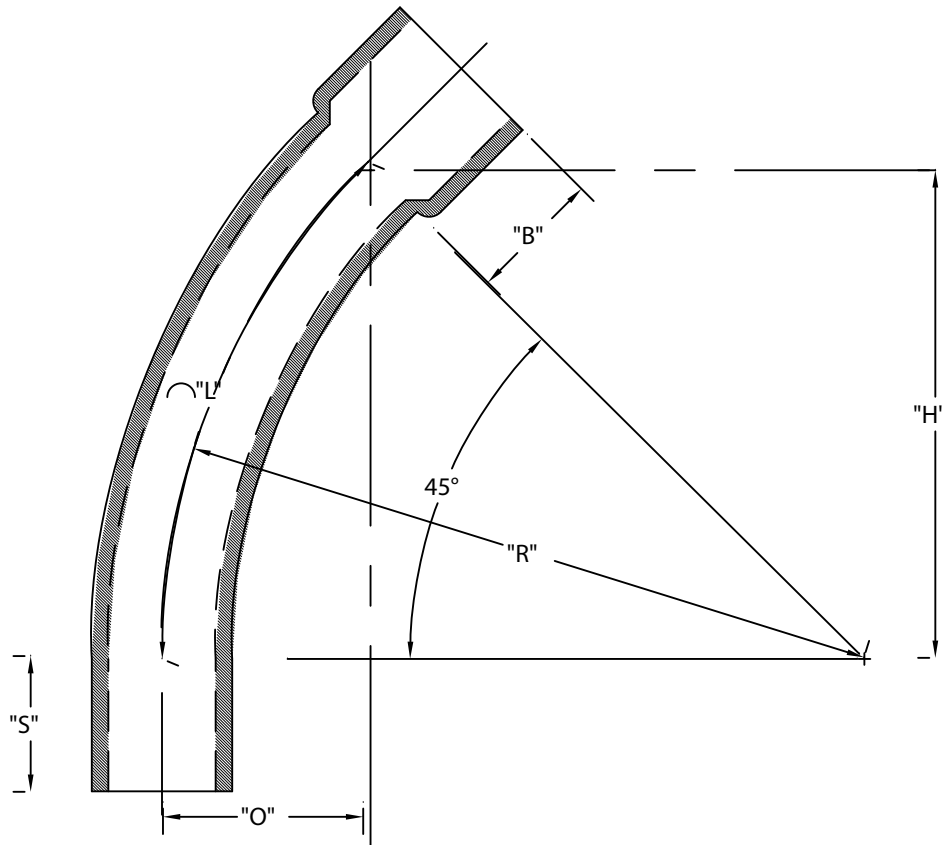

ETL LISTED
 CONFORMS TO UL651
 ETL CONTROL #3107144
 CONFORMS TO NEMA TC3
 SEE NEC ARTICLE 352 FOR USE
 MATERIAL IS RIGID PVC
 BEND TOLERANCE IS $\pm 2^\circ$
 "B" TOLERANCE IS $-\frac{1}{8}"$, $+\frac{1}{2}"$



CANTEX
 INC.
 Fort Worth, TEXAS

45° Elbows Bell End
 Schedule 40 30" Radius Elbows

Drawn By: CD Branch

Date: 10/15/07

Ref.