

PART NUMBER	SIZE	"R"	"O"	"H"	"S" MIN	"B" MIN	"L"
5133919	1"	36"	10 ½ "	25 ½ "	1 ⅞ "	N/A	28 ¼ "
5133956	1 ¼ "	36"	10 ½ "	25 ½ "	2"	N/A	28 ¼ "
5133810	1 ½ "	36"	10 ½ "	25 ½ "	2"	N/A	28 ¼ "
5133778	2"	36"	10 ½ "	25 ½ "	2"	N/A	28 ¼ "
5133801	2 ½ "	36"	10 ½ "	25 ½ "	3"	N/A	28 ¼ "
5133779	3"	36"	10 ½ "	25 ½ "	3 ⅛ "	N/A	28 ¼ "
5133939	3 ½ "	36"	10 ½ "	25 ½ "	3 ¼ "	N/A	28 ¼ "
5133777	4"	36"	10 ½ "	25 ½ "	3 ⅜ "	N/A	28 ¼ "
5133780	5"	36"	10 ½ "	25 ½ "	3 ⅝ "	N/A	28 ¼ "
5133880	6"	36"	10 ½ "	25 ½ "	3 ¾ "	N/A	28 ¼ "
5133988	8"	36"	10 ½ "	25 ½ "	6 ⅝ "	N/A	28 ¼ "

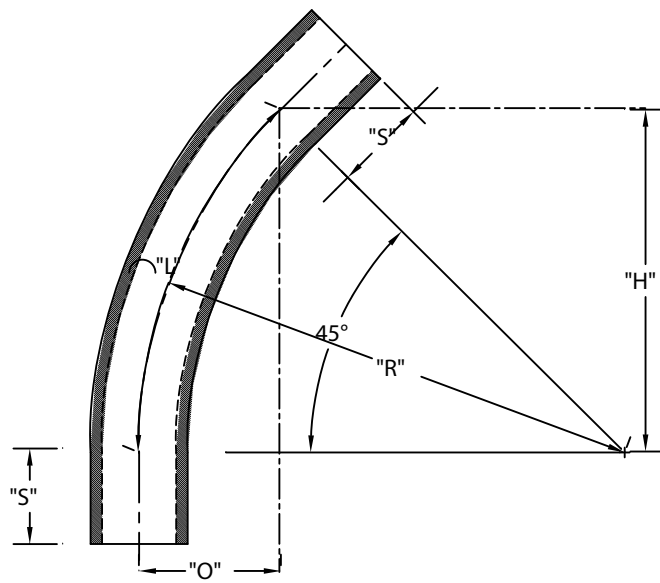

ETL LISTED
 CONFORMS TO UL651
 ETL CONTROL #3107144
 CONFORMS TO NEMA TC3
 SEE NEC ARTICLE 352 FOR USE
 MATERIAL IS RIGID PVC
 BEND TOLERANCE IS ±2°



45° Elbows Plain End
 Schedule 40 36" Radius Elbows

Drawn By: CD Branch

Date: 10/15/07

Ref.