

PART NUMBER	SIZE	"R"	"O"	"H"	"S" MIN	"B" MIN	"L"
5133998	1 1/4"	48"	15/16"	9 3/8"	2"	N/A	9 7/16"
5134039	2 1/2"	48"	15/16"	9 3/8"	3"	N/A	9 7/16"
5134083	3"	48"	15/16"	9 3/8"	3 1/8"	N/A	9 7/16"
5133990	4"	48"	15/16"	9 3/8"	3 3/8"	N/A	9 7/16"
5133977	5"	48"	15/16"	9 3/8"	3 5/8"	N/A	9 7/16"
5134079	6"	48"	15/16"	9 3/8"	3 3/4"	N/A	9 7/16"
5133907	8"	48"	15/16"	9 3/8"	6 5/8"	N/A	9 7/16"

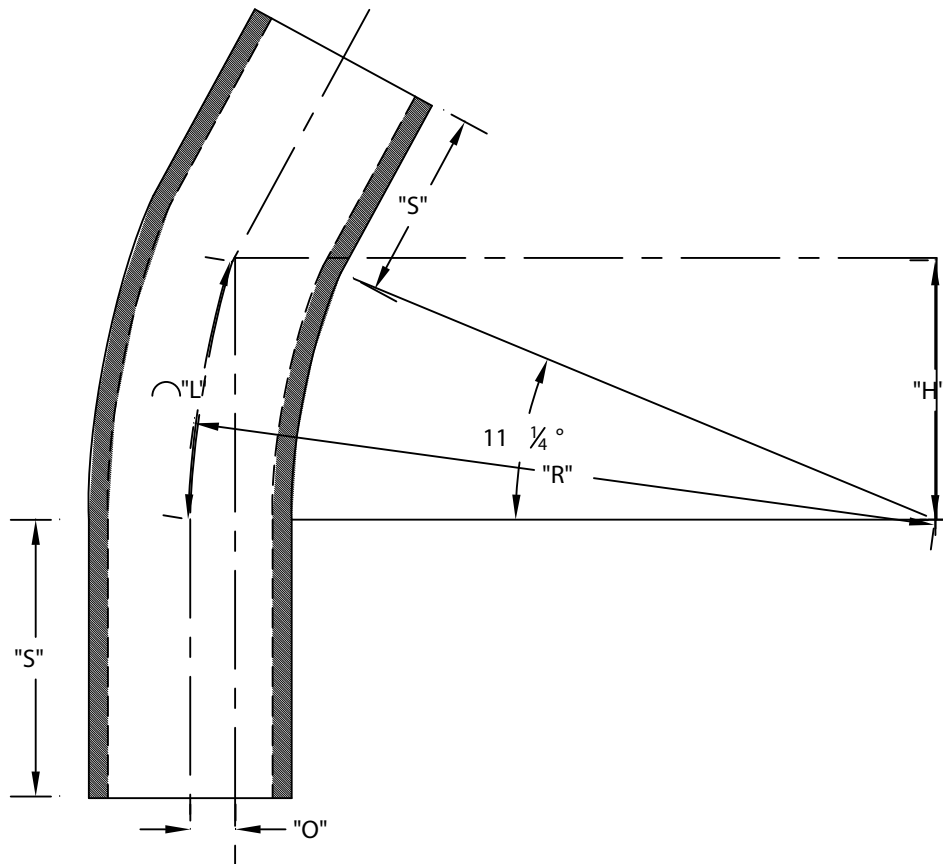

ETL LISTED  
 CONFORMS TO UL651  
 ETL CONTROL #3107144  
 CONFORMS TO NEMA TC3  
 SEE NEC ARTICLE 352 FOR USE  
 MATERIAL IS RIGID PVC  
 BEND TOLERANCE IS  $\pm 2^\circ$



**CANTEX**  
 INC.  
 Fort Worth, TEXAS

11 1/4° Elbows Plain End  
 Schedule 40 48" Radius Elbows

Drawn By: CD Branch

Date: 10/15/07

Ref.