

PART NUMBER	SIZE	"R"	"O"	"H"	"S" MIN	"B" MIN	"L"
5136340	1"	30"	30"	30"	1 7/8"	N/A	47 1/8"
5133878	1 1/4"	30"	30"	30"	2"	N/A	47 1/8"
5133921	1 1/2"	30"	30"	30"	2"	N/A	47 1/8"
5133920	2"	30"	30"	30"	2"	N/A	47 1/8"
5133981	2 1/2"	30"	30"	30"	3"	N/A	47 1/8"
5133867	3"	30"	30"	30"	3 1/8"	N/A	47 1/8"
5133850	4"	30"	30"	30"	3 3/8"	N/A	47 1/8"
5133872	5"	30"	30"	30"	3 5/8"	N/A	47 1/8"

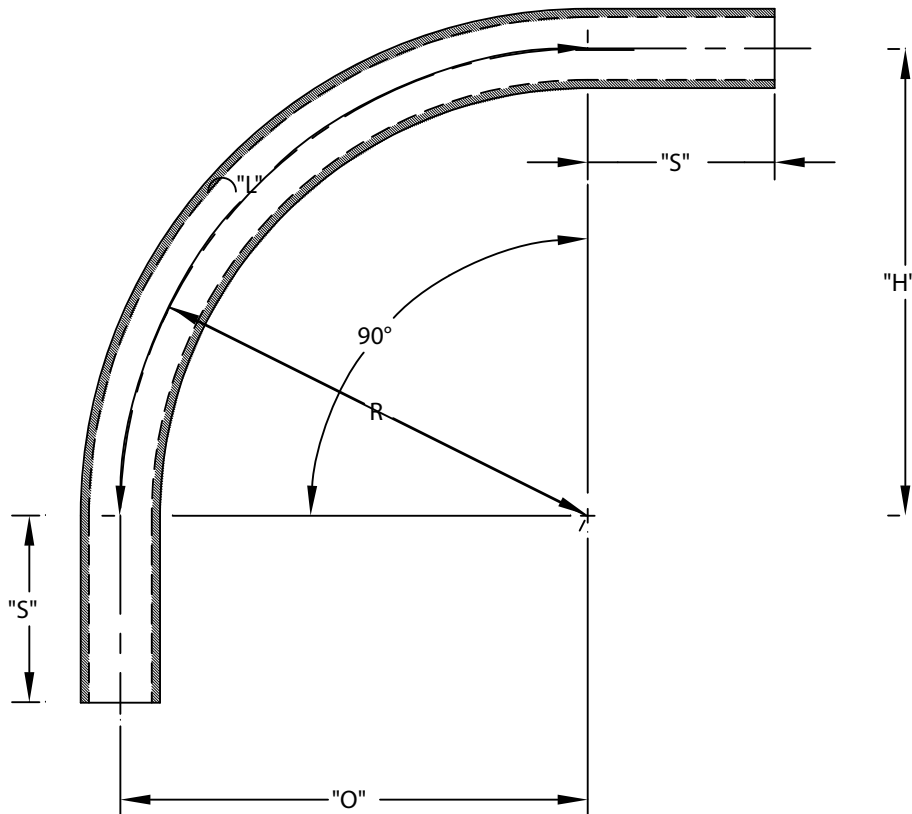

ETL LISTED
 CONFORMS TO UL651
 ETL CONTROL #3107144
 CONFORMS TO NEMA TC3
 SEE NEC ARTICLE 352 FOR USE
 MATERIAL IS RIGID PVC
 BEND TOLERANCE IS $\pm 2^\circ$



CANTEX
INC.
Fort Worth, TEXAS

90° Elbows Plain End
Schedule 40 30" Radius Elbows

Drawn By: CD Branch

Date: 10/15/07

Ref.