

PART NUMBER	SIZE	"R"	"O"	"H"	"S" MIN	"B" MIN	"L"
5136422	1"	48"	3 5/8"	18 3/8"	1 7/8"	N/A	18 7/8"
5136427	1 1/4"	48"	3 5/8"	18 3/8"	2"	N/A	18 7/8"
5136431	1 1/2"	48"	3 5/8"	18 3/8"	2"	N/A	18 7/8"
5133984	2"	48"	3 5/8"	18 3/8"	2"	N/A	18 7/8"
5136434	2 1/2"	48"	3 5/8"	18 3/8"	3"	N/A	18 7/8"
5133971	3"	48"	3 5/8"	18 3/8"	3 1/8"	N/A	18 7/8"
5136438	3 1/2"	48"	3 5/8"	18 3/8"	3 1/4"	N/A	18 7/8"
5133932	4"	48"	3 5/8"	18 3/8"	3 3/8"	N/A	18 7/8"
5133930	5"	48"	3 5/8"	18 3/8"	3 5/8"	N/A	18 7/8"
5133862	6"	48"	3 5/8"	18 3/8"	3 3/4"	N/A	18 7/8"

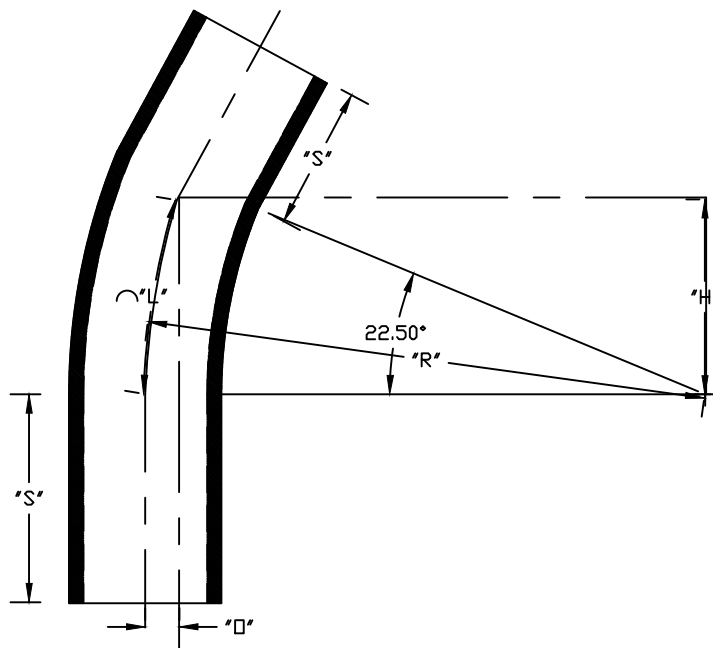

ETL LISTED  
 CONFORMS TO UL651  
 ETL CONTROL #3107144  
 CONFORMS TO NEMA TC3  
 SEE NEC ARTICLE 352 FOR USE  
 MATERIAL IS RIGID PVC  
 BEND TOLERANCE IS ±2°



<b>CANTEX</b> INC. Fort Worth, TEXAS		
22-1/2° Elbows Plain End Schedule 40 48" Radius Elbows		
Drawn By: O.M.	Date: 5/12/17	Ref. 5133984