

PART NUMBER	SIZE	"R"	"O"	"H"	"S" MIN	"B" MIN	"L"
5133951	4"	150"	43 ¹⁵ / ₁₆ "	106"	3 ³ / ₈ "	N/A	117 ¹³ / ₁₆ "
5133804	6"	150"	43 ¹⁵ / ₁₆ "	106"	3 ³ / ₄ "	N/A	117 ¹³ / ₁₆ "

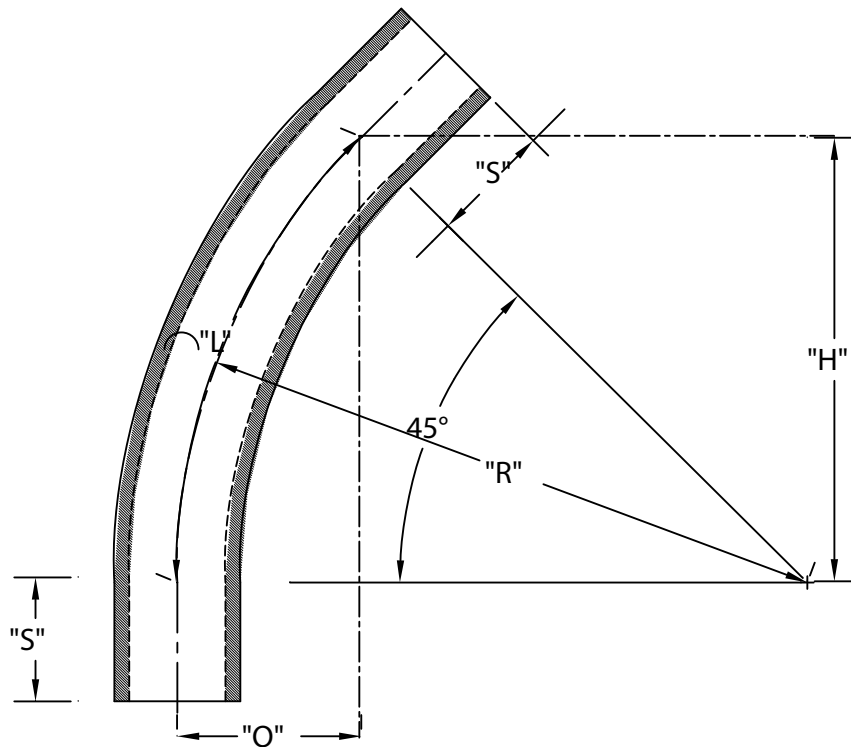

ETL LISTED
 CONFORMS TO UL651
 ETL CONTROL #3107144
 CONFORMS TO NEMA TC3
 SEE NEC ARTICLE 352 FOR USE
 MATERIAL IS RIGID PVC
 BEND TOLERANCE IS ±2°



CANTEX
 INC.
 Fort Worth, TEXAS

45° Elbows Plain End
 Schedule 40 150" Radius Elbows

Drawn By: CD Branch

Date: 10/15/07

Ref.