

PART NUMBER	SIZE	"R"	"O"	"H"	"S" MIN	"B" MIN	"L"
5133875	1"	24"	17"	7"	1 $\frac{7}{8}$ "	N/A	18 $\frac{7}{8}$ "
5133941	1 $\frac{1}{4}$ "	24"	17"	7"	2"	N/A	18 $\frac{7}{8}$ "
5133874	1 $\frac{1}{2}$ "	24"	17"	7"	2"	N/A	18 $\frac{7}{8}$ "
5133815	2"	24"	17"	7"	2"	N/A	18 $\frac{7}{8}$ "
5133935	2 $\frac{1}{2}$ "	24"	17"	7"	3"	N/A	18 $\frac{7}{8}$ "
5133800	3"	24"	17"	7"	3 $\frac{1}{8}$ "	N/A	18 $\frac{7}{8}$ "
5133802	3 $\frac{1}{2}$ "	24"	17"	7"	3 $\frac{1}{4}$ "	N/A	18 $\frac{7}{8}$ "
5133812	4"	24"	17"	7"	3 $\frac{3}{8}$ "	N/A	18 $\frac{7}{8}$ "

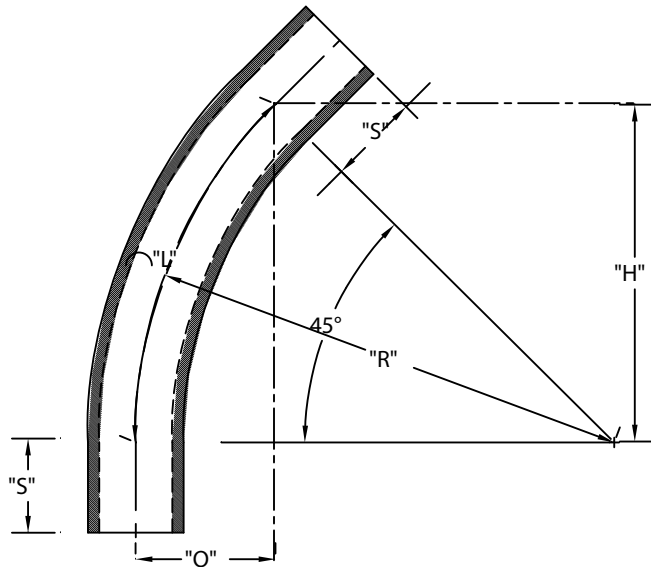

ETL LISTED
 CONFORMS TO UL651
 ETL CONTROL #3107144
 CONFORMS TO NEMA TC3
 SEE NEC ARTICLE 352 FOR USE
 MATERIAL IS RIGID PVC
 BEND TOLERANCE IS $\pm 2^\circ$



CANTEX
 INC.
 Fort Worth, TEXAS

45° Elbows Plain End
 Schedule 40 24" Radius Elbows

Drawn By: CD Branch

Date: 10/15/07

Ref.