

PART NUMBRT	SIZE	"R"	"O"	"H"	"S" MIN	"B" MIN	"L"
5125756	2"	24"	15/32"	11/16"	2"	2"	4 23/32"
5125820	4"	24"	15/32"	11/16"	3 3/8"	3 1/4"	4 23/32"

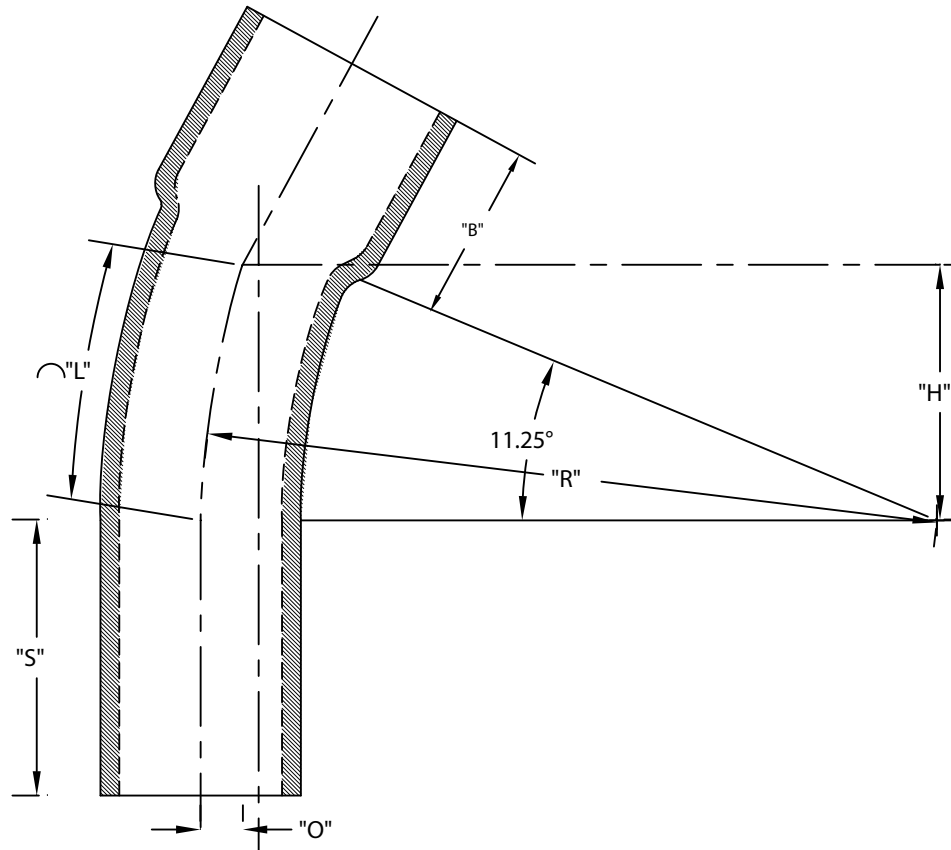

CONFORMS TO NEMA TC 6&8
MATERIAL IS HIGH MODULUS (HM) 500,000 psi
BEND TOLERANCE IS ±2°
"B" TOLERANCE IS -1/8", +1/2"

CANTEX

INC.
Fort Worth, TEXAS

11 1/4° Elbows Bell End
DB120 24" Radius Elbows

Drawn By: CD Branch

Date: 10/04/10

Ref.