

PART NUMBRT	SIZE	"R"	"O"	"H"	"S" MIN	"B" MIN	"L"
5125819	4"	60"	8 1/16"	30"	3 5/8"	3 1/4"	31 7/16"
5125803	5"	60"	8 1/16"	30"	3 3/4"	4 1/4"	31 7/16"

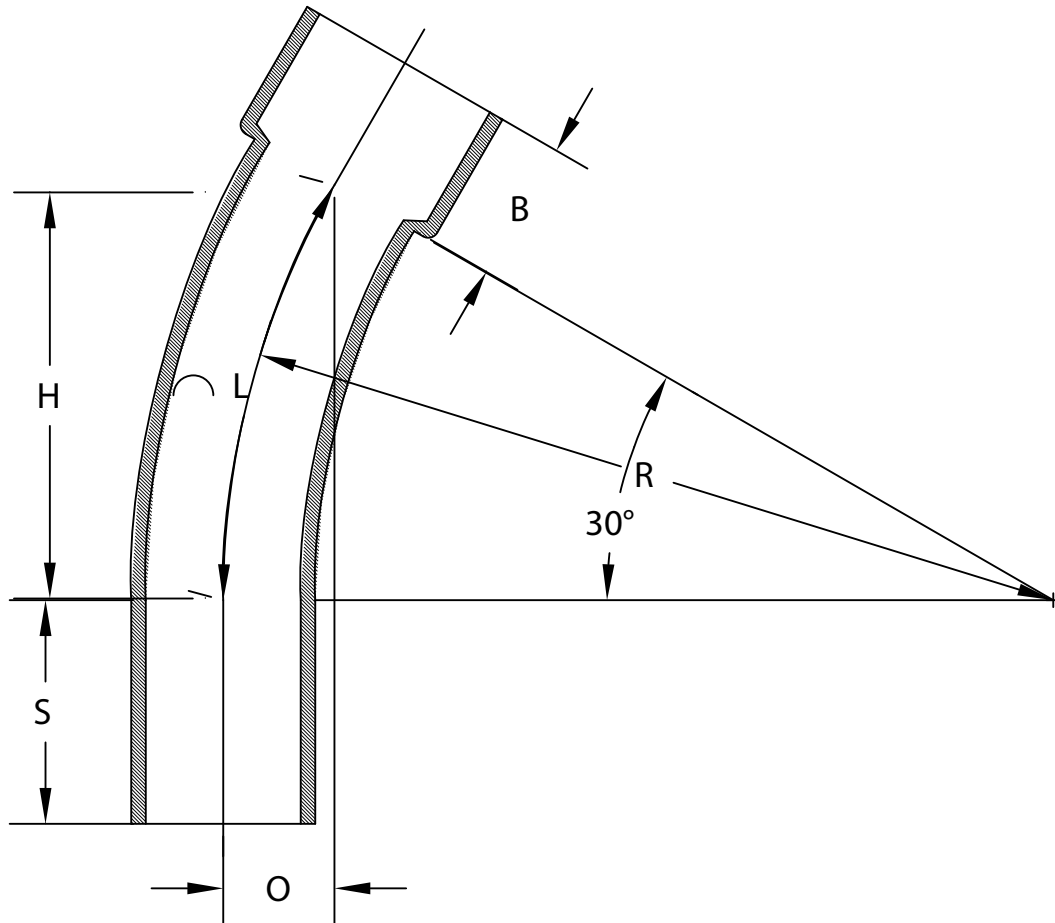

CONFORMS TO NEMA TC 6&8  
MATERIAL IS HIGH MODULUS (HM) 500,000 psi  
BEND TOLERANCE IS  $\pm 2^\circ$   
"B" TOLERANCE IS  $-\frac{1}{8}'' + \frac{1}{2}''$

**CANTEX**  
INC.

Fort Worth, TEXAS

30° ELBOWS BELL END  
DB120 60" RADIUS

Drawn By: CD Branch

Date: 10/15/07

Ref.