

PART NUMBRT	SIZE	"R"	"O"	"H"	"S" MIN	"B" MIN	"L"
5125763	2"	24"	1 ¹³ / ₁₆ "	9 ³ / ₁₆ "	2"	2"	9 ⁷ / ₁₆ "
5125805	3"	24"	1 ¹³ / ₁₆ "	9 ³ / ₁₆ "	3 ¹ / ₈ "	1 ¹ / ₂ "	9 ⁷ / ₁₆ "
5125794	4"	24"	1 ¹³ / ₁₆ "	9 ³ / ₁₆ "	3 ³ / ₈ "	3 ¹ / ₄ "	9 ⁷ / ₁₆ "
5125801	5"	24"	1 ¹³ / ₁₆ "	9 ³ / ₁₆ "	3 ³ / ₄ "	4 ¹ / ₄ "	9 ⁷ / ₁₆ "

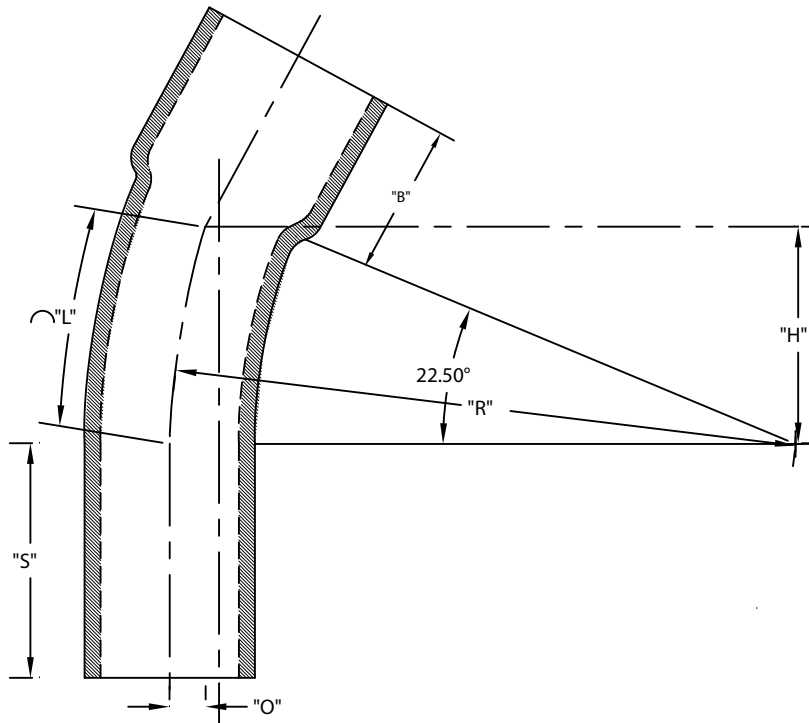

CONFORMS TO NEMA TC 6&8
MATERIAL IS HIGH MODULUS (HM) 500,000 psi
BEND TOLERANCE IS $\pm 2^\circ$
"B" TOLERANCE IS $-1/8", +1/2"$

CANTEX
INC.
Fort Worth, TEXAS

22-1/2° Elbows Bell End
DB120 24" Radius Elbows

Drawn By: CD Branch

Date: 10/15/07

Ref.