

PART NUMBRT	SIZE	"R"	"O"	"H"	"S" MIN	"B" MIN	"L"
5125751	2"	18"	2 7/16"	9 1/16"	2"	2"	9 7/16"
5125841	3"	18"	2 7/16"	9 1/16"	3 1/8"	2 1/2"	9 7/16"

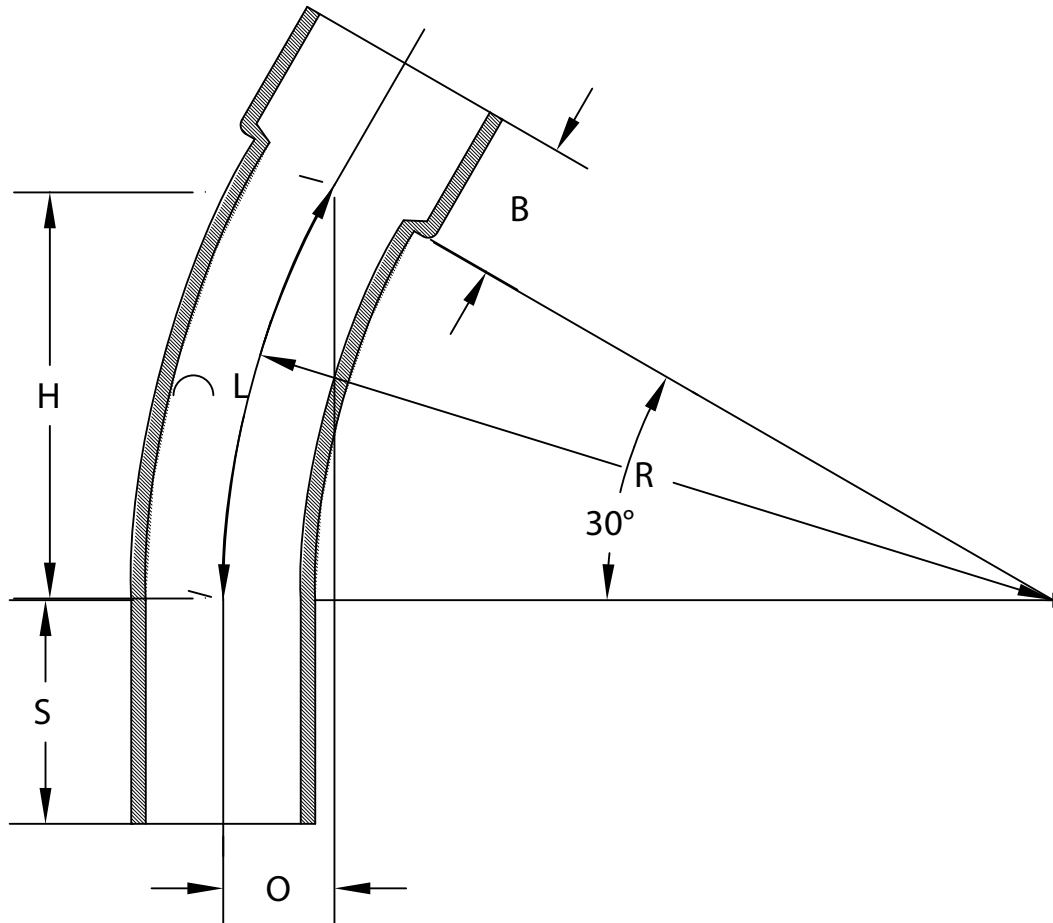

CONFORMS TO NEMA TC 6&8
MATERIAL IS HIGH MODULUS (HM) 500,000 psi
BEND TOLERANCE IS $\pm 2^\circ$
"B" TOLERANCE IS $-\frac{1}{8}"$, $+\frac{1}{2}"$

CANTEX
INC.

Fort Worth, TEXAS

30° Elbows Bell End
DB120 18" Radius Elbows

Drawn By: CD Branch

Date: 10/15/07

Ref.