

PART NUMBRT	SIZE	"R"	"O"	"H"	"S" MIN	"B" MIN	"L"
5123748	4"	60"	8 1/16"	30"	3 3/8"	3 1/4"	31 7/16"
5123782	5"	60"	8 1/16"	30"	3 5/8"	4 1/4"	31 7/16"
5123795	6"	60"	8 1/16"	30"	3 3/4"	5"	31 7/16"

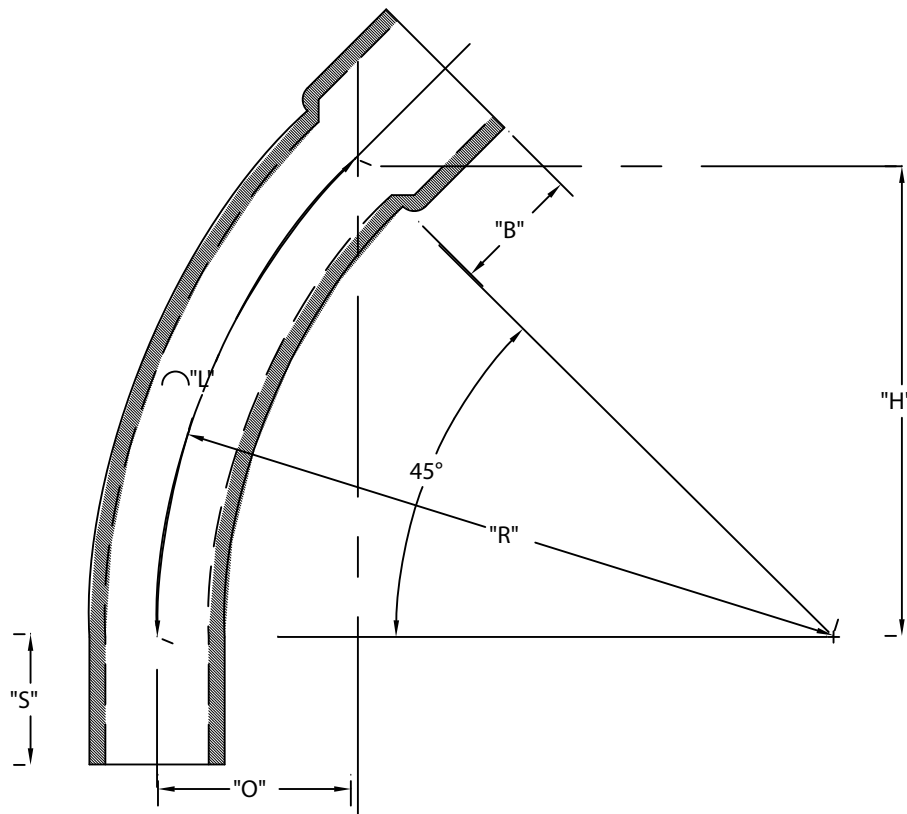

CONFORMS TO NEMA TC 6&8
MATERIAL IS HIGH MODULUS (HM) 500,000 psi
BEND TOLERANCE IS $\pm 2^\circ$
"B" TOLERANCE IS $-\frac{1}{8}"$, $+\frac{1}{2}"$

CANTEX

INC.

Fort Worth, TEXAS

45° Elbows Bell End
DB60 60" Radius Elbows

Drawn By: CD Branch

Date: 10/15/07

Ref.