

PART NUMBER	SIZE	"R"	"O"	"H"	"S" MIN	"B" MIN	"L"
5123779	4"	48"	6 7/16"	24"	3 3/8"	3 1/4"	25 1/8"
5123781	5"	48"	6 7/16"	24"	3 5/8"	4 1/4"	25 1/8"
5123794	6"	48"	6 7/16"	24"	3 3/4"	5"	25 1/8"

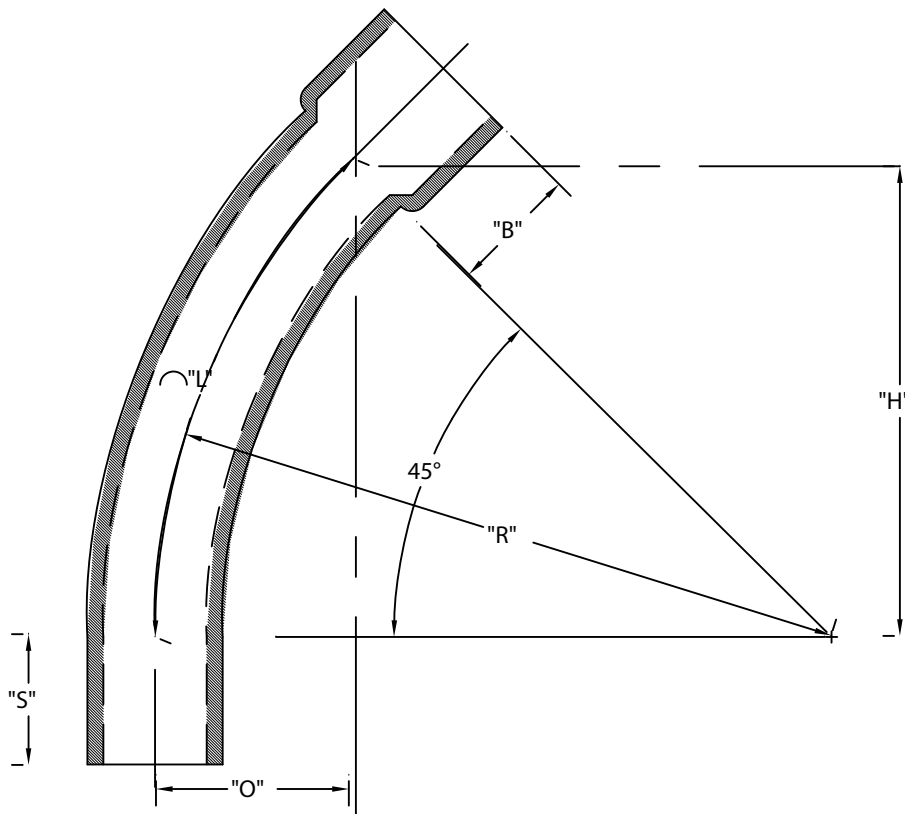

CONFORMS TO NEMA TC 6&8
 MATERIAL IS HIGH MODULUS (HM) 500,000 psi
 BEND TOLERANCE IS $\pm 2^\circ$
 "B" TOLERANCE IS $-1/8", +1/2"$

CANTEX
 INC.
 Fort Worth, TEXAS

45° Elbows Bell End
 DB60 48" Radius Elbows

Drawn By: CD Branch

Date: 10/15/07

Ref.