

PART NUMBER	SIZE	"R"	"D"	"H"	"S" MIN	"B" MIN	"L"
5123702	2"	150"	2 7/8"	29 1/4"	2"	1 3/4 "	29 7/16"
5123703	3"	150"	2 7/8"	29 1/4"	3 1/8"	2 1/2 "	29 7/16"
5123705	4"	150"	2 7/8"	29 1/4"	3 3/8"	3 1/4 "	29 7/16"
7123792	5"	150"	2 7/8"	29 1/4"	3 5/8"	4 1/4 "	29 7/16"
5123733	6"	150"	2 7/8"	29 1/4"	3 3/4"	5"	29 7/16"

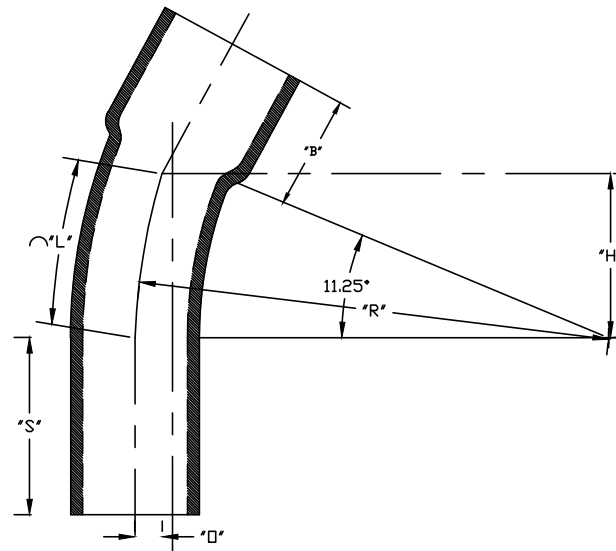

Meets NEMA TC3  
Material is Rigid PVC  
Bend Tolerance is  $\pm 2^\circ$

<b>CANTEX</b> INC. Fort Worth, TEXAS		
11 1/4° Elbows Bell End DB-60 150" Radius Elbows		
Drawn By: D. Gwinn	Date: 4/22/19	Ref. 5123702