

PART NUMBRT	SIZE	"R"	"O"	"H"	"S" MIN	"B" MIN	"L"
5123800	2"	36"	2 ³ / ₄ "	13 ³ / ₄ "	2"	2"	14 ¹ / ₈ "
5123755	3"	36"	2 ³ / ₄ "	13 ³ / ₄ "	3 ¹ / ₈ "	2 ¹ / ₂ "	14 ¹ / ₈ "
5123750	4"	36"	2 ³ / ₄ "	13 ³ / ₄ "	3 ³ / ₈ "	3 ¹ / ₄ "	14 ¹ / ₈ "
5123751	5"	36"	2 ³ / ₄ "	13 ³ / ₄ "	3 ⁵ / ₈ "	4 ¹ / ₄ "	14 ¹ / ₈ "
5123730	6"	36"	2 ³ / ₄ "	13 ³ / ₄ "	3 ³ / ₄ "	5"	14 ¹ / ₈ "

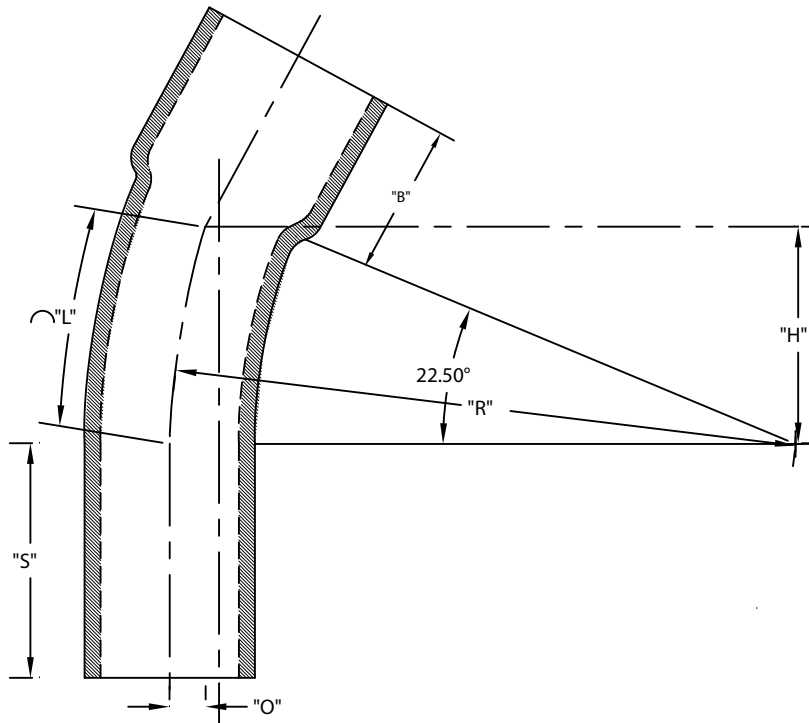

CONFORMS TO NEMA TC 6&8
MATERIAL IS HIGH MODULUS (HM) 500,000 psi
BEND TOLERANCE IS $\pm 2^\circ$
"B" TOLERANCE IS $-\frac{1}{8}"$, $+\frac{1}{2}"$

CANTEX
INC.
Fort Worth, TEXAS

22-1/2° Elbows Bell End
DB60 36" Radius Elbows

Drawn By: CD Branch

Date: 10/15/07

Ref.