

PART NUMBER	SIZE	"R"	"O"	"H"	"S" MIN	"B" MIN	"L"
5121949	5"	60"	17 $\frac{9}{16}$ "	42 $\frac{3}{8}$ "	3 $\frac{5}{8}$ "	4 $\frac{1}{4}$ "	47 $\frac{1}{8}$ "

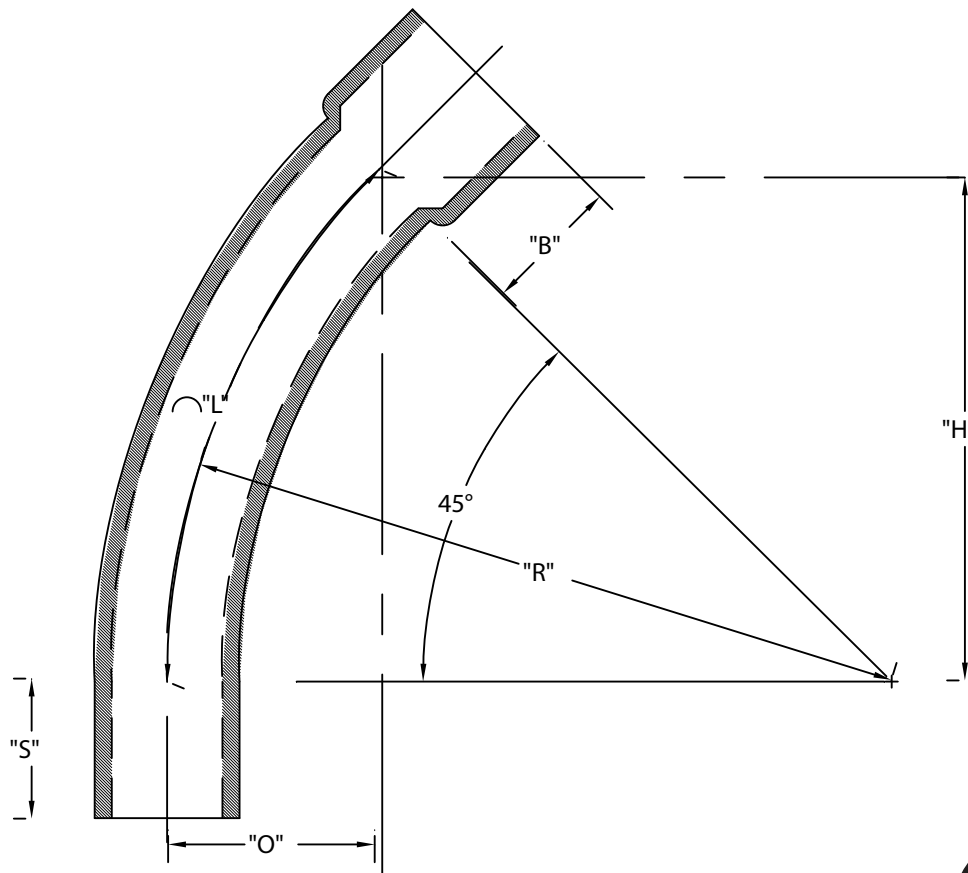

ETL LISTED
 CONFORMS TO UL651
 ETL CONTROL #3107144
 CONFORMS TO NEMA TC3
 SEE NEC ARTICLE 352 FOR USE
 MATERIAL IS RIGID PVC
 BEND TOLERANCE IS $\pm 2^\circ$
 "B" TOLERANCE IS $-\frac{1}{8}$ ", $+\frac{1}{2}$ "



CANTEX
 INC.
 Fort Worth, TEXAS

45° Elbows Bell End
 Schedule 80 60" Radius Elbows

Drawn By: CD Branch

Date: 10/15/07

Ref.