

PART NUMBER	SIZE	"R"	"O"	"H"	"S" MIN	"B" MIN	"L"
5121123	4"	48"	6 7/16 "	24"	3 3/8"	N/A	25 1/8 "
5121115	5"	48"	6 7/16 "	24"	3 5/8"	N/A	25 1/8 "

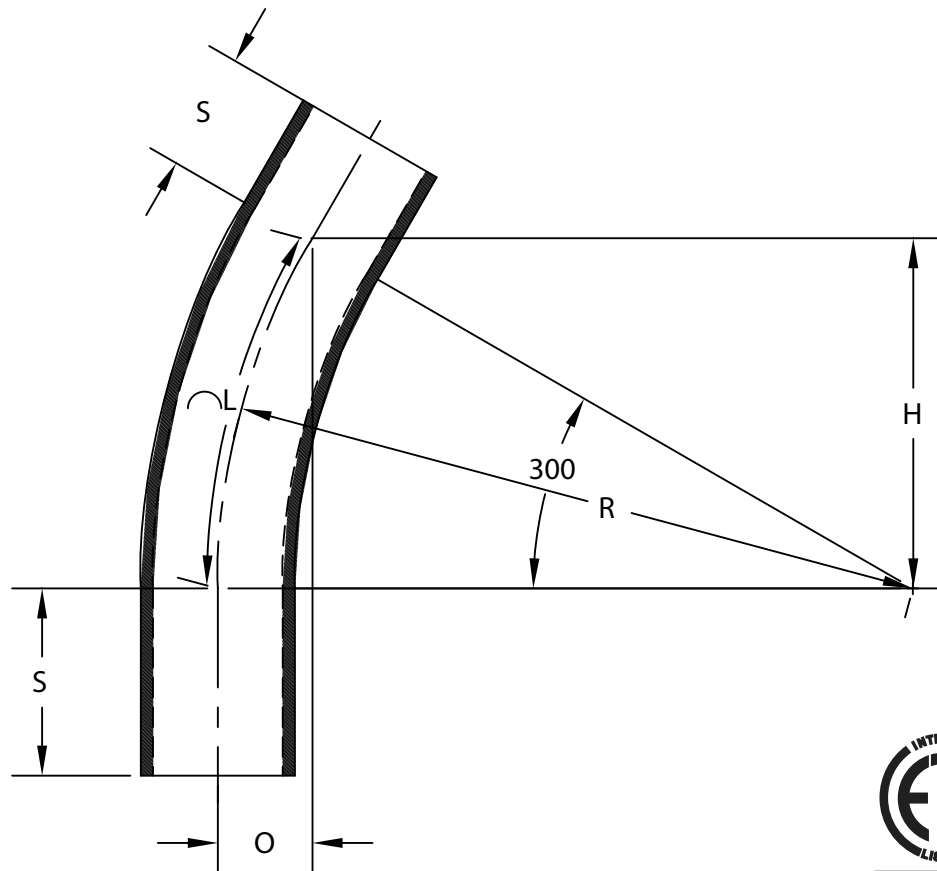

ETL LISTED  
 CONFORMS TO UL651  
 ETL CONTROL #3107144  
 CONFORMS TO NEMA TC3  
 SEE NEC ARTICLE 352 FOR USE  
 MATERIAL IS RIGID PVC  
 BEND TOLERANCE IS  $\pm 2^\circ$



**CANTEX**  
 INC.  
 Fort Worth, TEXAS

30° Elbows Plain End  
 Schedule 80 48" Radius Elbows

Drawn By: CD Branch

Date: 10/15/07

Ref.