

PART NUMBER	SIZE	"R"	"□"	"H"	"S" MIN	"B" MIN	"L"
5121000	½"	4"	½"	2"	1 ½"	N/A	2 ⅛"
5121001	¾"	4 ½"	⅝"	2 ¼"	1 ½"	N/A	2 ⅜"
5121002	1"	5 ¾"	¾"	2 ⅞"	1 ⅞"	N/A	3"
5121106	1 ¼"	7 ¼"	1"	3 ⅝"	2"	N/A	3 13/16"
5121850	1 ½"	8 ¼"	1 ⅛"	4 ⅛"	2"	N/A	4 ⅝"
5121108	2"	9 ½"	1 ¼"	4 ¾"	2"	N/A	5"
5121109	2 ½"	10 ½"	1 ⅞"	5 ¼"	3"	N/A	5 ½"
5121110	3"	13	1 ¾"	6 ½"	3 ⅛"	N/A	6 13/16"
5121111	4"	16	2 ⅛"	8"	3 ⅜"	N/A	8 ⅜"
5121112	5"	24	3 ⅜"	12"	3 ⅝"	N/A	12 9/16"
5121113	6"	30	4"	15"	3 ¾"	N/A	15 1/16"

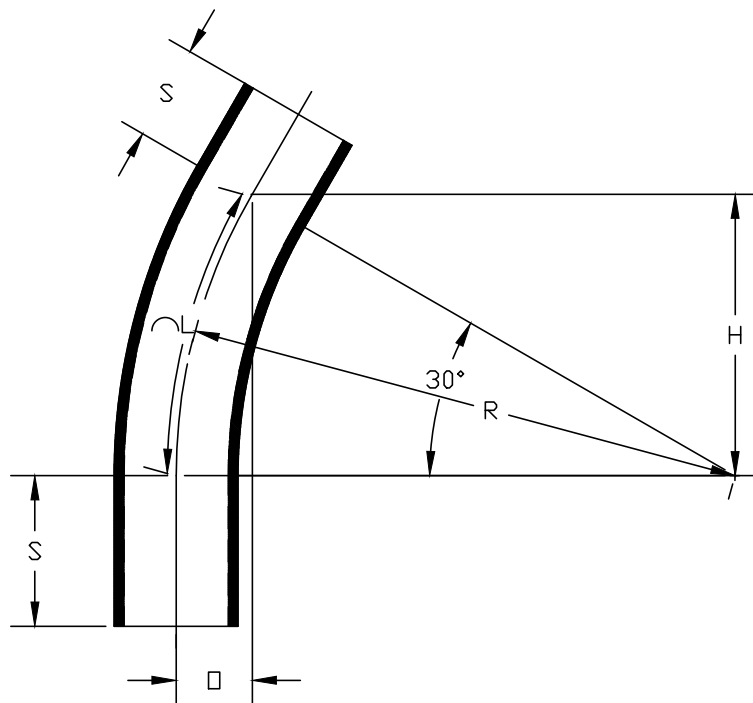

ETL LISTED  
 CONFORMS TO UL651  
 ETL CONTROL #3107144  
 CONFORMS TO NEMA TC3  
 SEE NEC ARTICLE 352 FOR USE  
 MATERIAL IS RIGID PVC  
 BEND TOLERANCE IS ±2°



**CANTEX**  
 INC.  
 Fort Worth, TEXAS

30° Elbows Plain End  
 Schedule 80 Standard Radius Elbows

Drawn By: CD Branch | Date:10/15/08 | Ref.