

PART NUMBER	SIZE	"R"	"O"	"H"	"S" MIN	"B" MIN	"L"
5221080	1"	36"	36"	36"	1 7/8"	1 1/2"	56 1/2"
5121049	1 1/2"	36"	36"	36"	2"	2"	56 1/2"
5121047	2"	36"	36"	36"	2"	2"	56 1/2"
5221100	2 1/2"	36"	36"	36"	3"	2 1/4"	56 1/2"
5121038	3"	36"	36"	36"	3 1/8"	2 1/2"	56 1/2"
5221023	4"	36"	36"	36"	3 3/8"	3 1/4"	56 1/2"
5221083	5"	36"	36"	36"	3 5/8"	4 1/4"	56 1/2"
5121045	6"	36"	36"	36"	3 3/4"	5"	56 1/2"

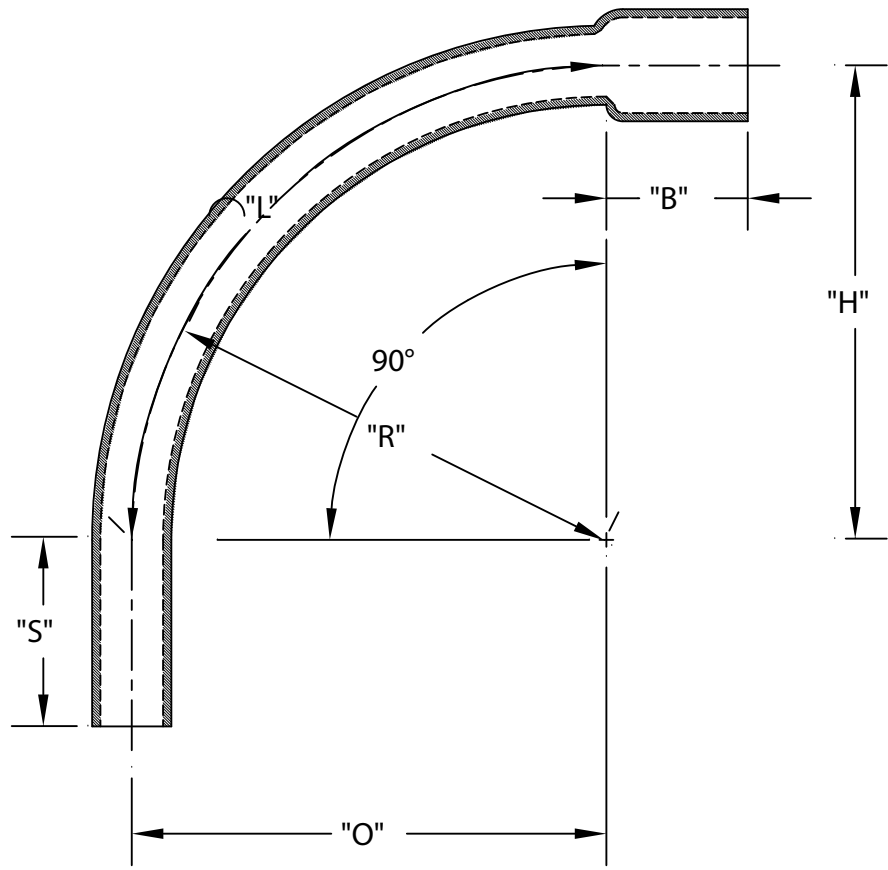

ETL LISTED
 CONFORMS TO UL651
 ETL CONTROL #3107144
 CONFORMS TO NEMA TC3
 SEE NEC ARTICLE 352 FOR USE
 MATERIAL IS RIGID PVC
 BEND TOLERANCE IS ±2°
 "B" TOLERANCE IS -1/8", +1/2"



CANTEX INC. Fort Worth, TEXAS		
90° Elbows Bell End Schedule 80 36" Radius Elbows		
Drawn By: CD Branch	Date: 10/15/07	Ref.